

SIGNAL ANALYZERS

Definitions

Spectrum Analyzer

- “A spectrum analyzer measures the magnitude of an input signal versus frequency within the full frequency range of the instrument. The primary use is to measure the power of the spectrum of known and unknown signals.”

Vector Signal Analyzer

- “A vector signal analyzer measures the magnitude and phase of an input signal at a single frequency within the IF bandwidth of the instrument. The primary use is to make in-channel measurements, such as error vector magnitude, code domain power, and spectral flatness, on known signals.”

Signal Analyzer

- “A signal analyzer provides the functions of a spectrum analyzer and a vector signal analyzer.”

Overview

Frequency versus Time Domain

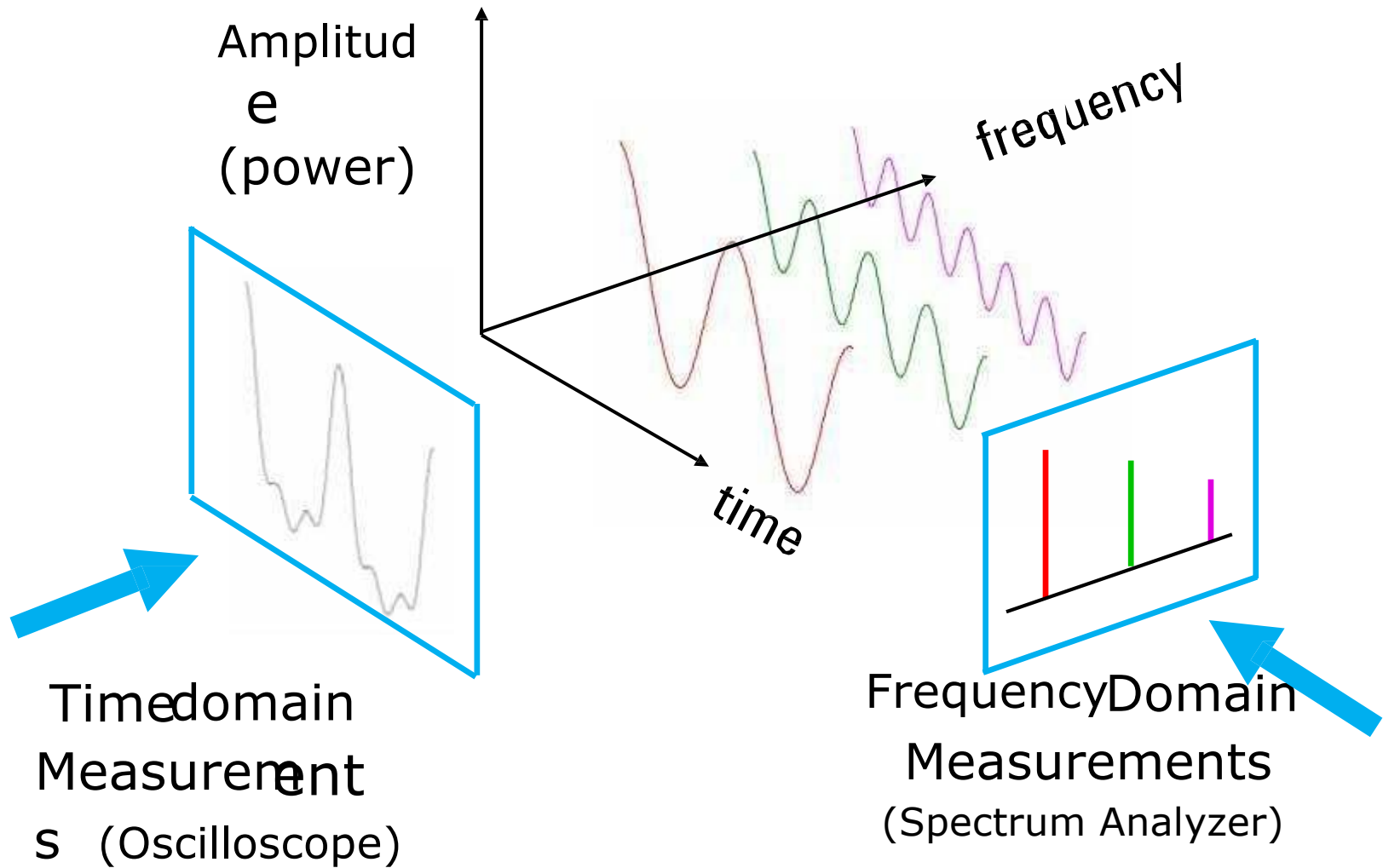

Overview

What is Spectrum Analysis?

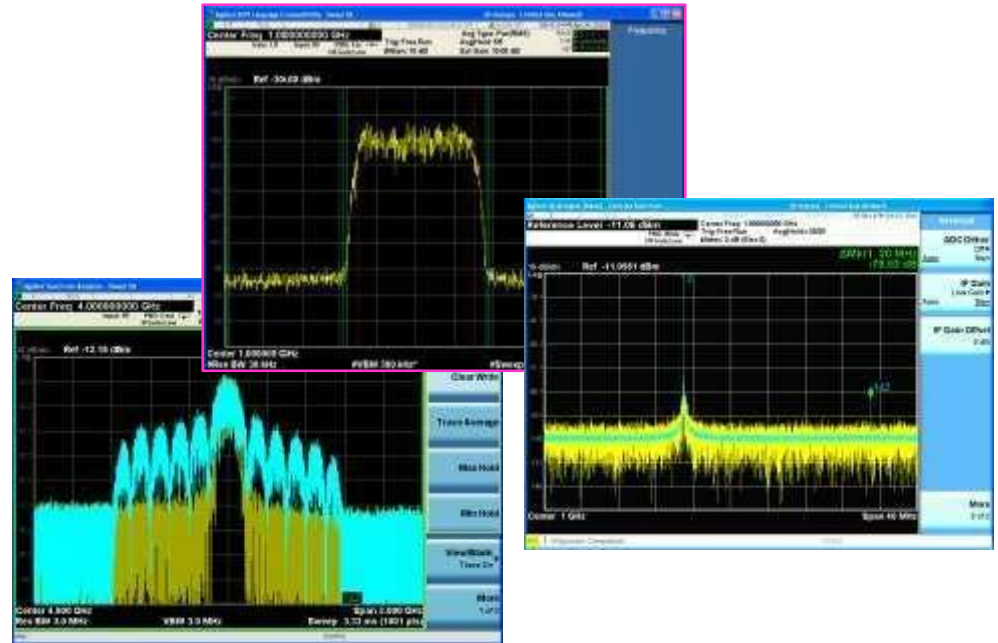

Distortion Analyzer

- Distortion – the alteration of the original shape of a waveform.
- Function of distortion analyzer: measuring the extent of distortion (the o/p differs from the waveform at the i/p) introduced by the active or passive devices.
- An amplitude distorted sine wave is made up of pure sine wave components, including the **fundamental** frequency, f of the input signal, and **harmonic** multiples of fundamental frequency, $2f$, $3f$, $4f$, etc.
- **Harmonic distortion** can be measured accurately using harmonic distortion analyzer, generally called a **distortion analyzer**.
- The **total harmonic distortion** (THD) is given by

$$\text{THD} = \frac{\sqrt{\sum (\text{harmonics rms})^2}}{\text{fundamental rms}}$$

The total harmonic distortion (THD) can also be written as :

$$\text{THD} = \frac{\sqrt{E_2^2 + E_3^2 + \dots + E_n^2}}{E_f}$$

where

THD = the total harmonic distortion

E_f = the amplitude of fundamental frequency
including the harmonics

$E_2, E_3 \dots, E_n$ = the amplitude of the individual
harmonics

Example 1:

Compute the THD of a signal that contains a fundamental signal of $E_1 = 10V_{\text{rms}}$, harmonics $E_2 = 3V_{\text{rms}}$, $E_3 = 1.5V_{\text{rms}}$, and $E_4 = 0.6V_{\text{rms}}$.

Solution :

$$\begin{aligned}\text{THD} &= \frac{\sqrt{(3V)^2 + (1.5V)^2 + (0.6V)^2}}{10V} \\ &= 34.07\%\end{aligned}$$

Wave Analyzer

- A harmonic distortion analyzer measures the total harmonic content in a waveform.
- Any complex waveform is made up of a **fundamental** and its **harmonics**.
- **Wave analyzer** is used to measure the **amplitude** of each harmonic or fundamental frequency individually.
- Wave analyzers are also referred to as frequency selective voltmeters, carrier frequency voltmeters, and selective level voltmeters.
- The instrument is tuned to the frequency of one component whose amplitude is measured.
- Some wave analyzers have the **automatic frequency control** which tunes to the signal automatically.

Wave Analyzer

Circuit:

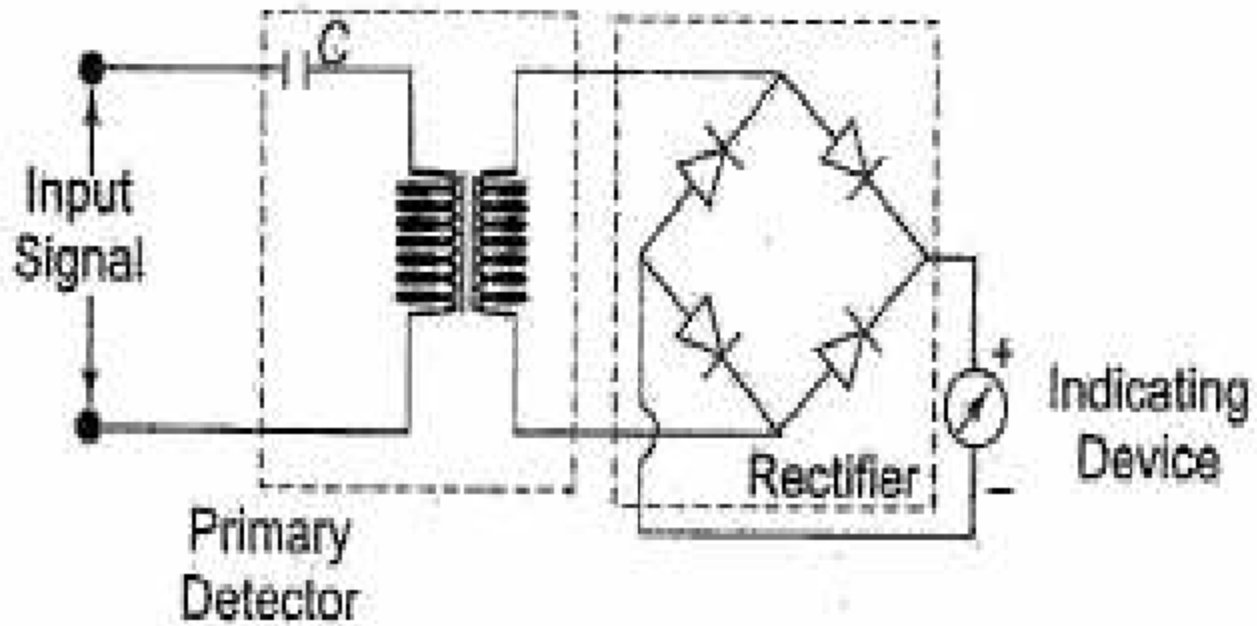

Working process for wave analyzer

- The analyzer consists of a primary detector, which is a simple **LC circuit**.
- The LC circuit is adjusted for resonance at the frequency of the particular harmonic component to be measured.
- It passes only the frequency to which it is tuned and provides a high attenuation to all other frequencies.
- The **full wave rectifier** is used to get the average value of the input signal.
- The indicating device is a simple dc voltmeter that is calibrated to read the peak value of the sinusoidal input voltage.

Frequency wave analyzer

- The wave analyzer consists of a very narrow pass-band filter section which can be tuned to a particular frequency within the audible frequency range (20 Hz to 20 KHz).

Block Diagram

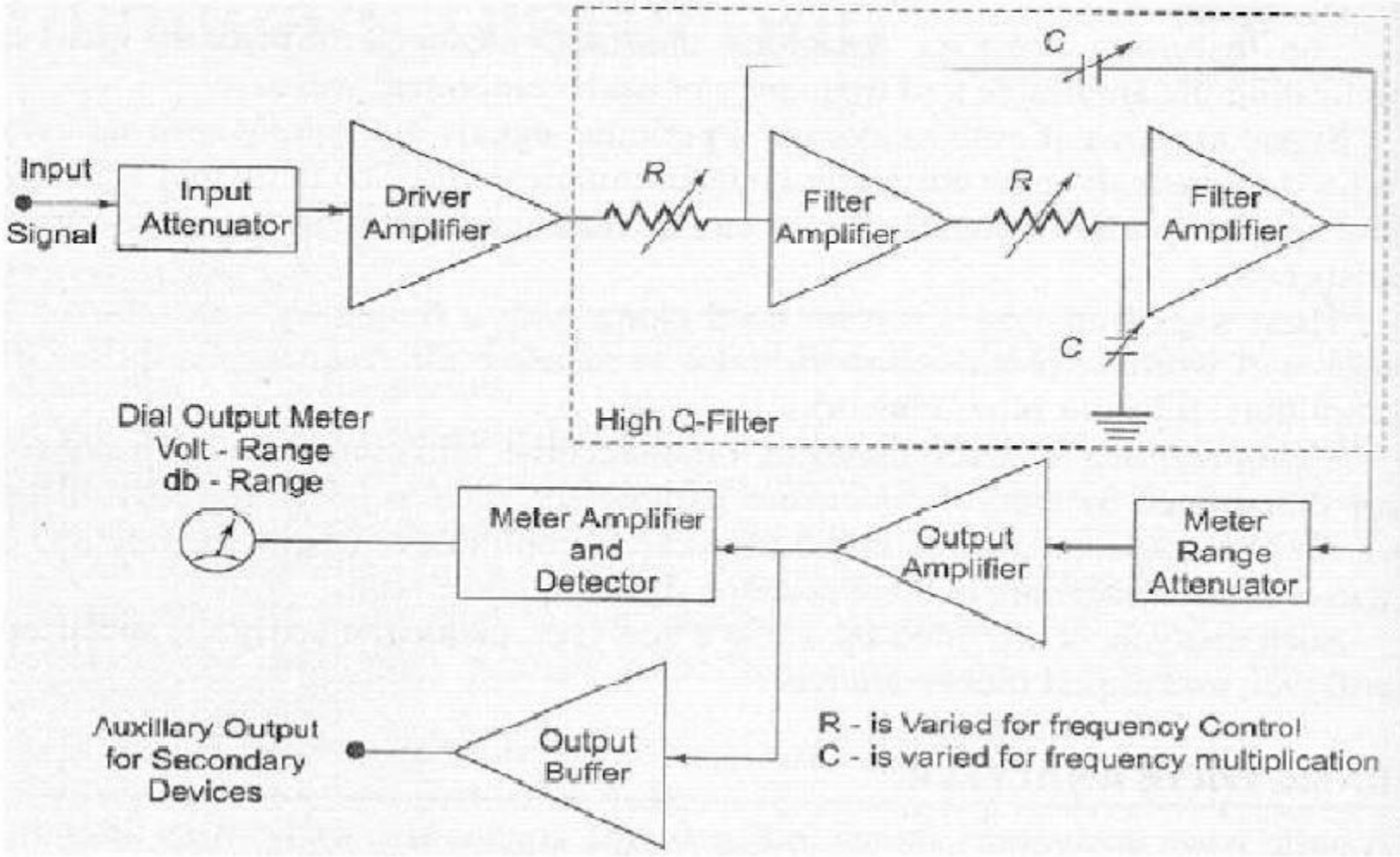

- The complex wave to be analyzed is passed through an adjustable attenuator which serves as a range multiplier and permits a large range of signal amplitudes to be analyzed without loading the amplifier.
- The output of the attenuator is then fed to a selective amplifier, which amplifies the selected frequency. The driver amplifier applies the attenuated input signal to a high-Q active filter.
- This high-Q filter is a low pass filter which allows the frequency which is selected to pass and reject all others.

- The magnitude of this selected frequency is indicated by the meter and the filter section identifies the frequency of the component.
- The filter circuit consists of a cascaded RC resonant circuit and amplifiers.
- For selecting the frequency range, the capacitors generally used are of the closed tolerance polystyrene type and the resistances used are precision potentiometers.
- The capacitors are used for range changing and the potentiometer is used to change the frequency within the selected pass-band, Hence this wave analyzer is also called a Frequency selective voltmeter.

- The selected signal output from the final amplifier stage is applied to the meter circuit and to an unturned buffer amplifier.
- The main function of the buffer amplifier is to drive output devices, such as recorders or electronics counters.
- The meter has several voltage ranges as well as decibel scales marked on it. It is driven by an average reading rectifier type detector.
- The wave analyzer must have extremely low input distortion.
- The band width of the instrument is very narrow typically about 1% of the selective band

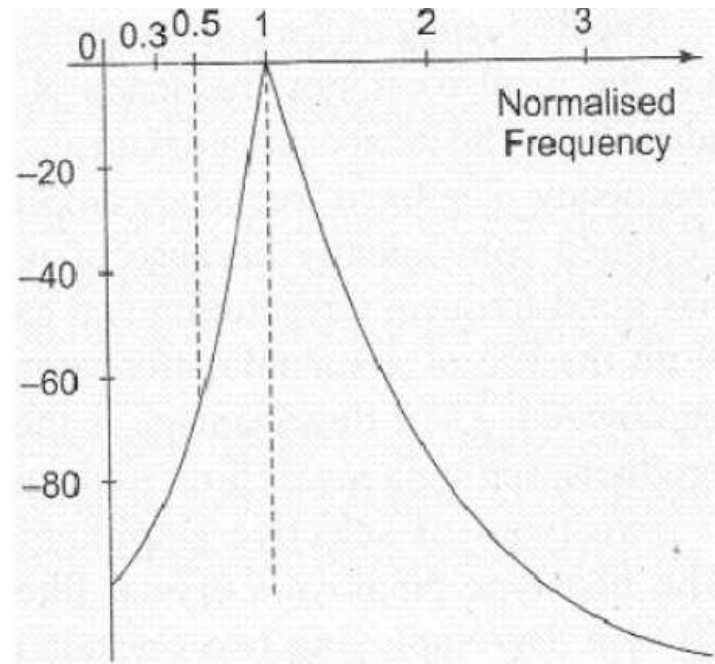

Application of wave analyzer

- 1. Electrical measurements
- 2. Sound measurements
- 3. Vibration measurements.

Heterodyne wave analyzer

- A wave analyzer, in fact, is an instrument designed to measure relative amplitudes of single frequency components in a complex waveform. Basically, the instrument acts as a frequency selective voltmeter which is used to the frequency of one signal while rejecting all other signal components.
- The desired frequency is selected by a frequency calibrated dial to the point of maximum amplitude. The amplitude is indicated either by a suitable voltmeter or CRO. This instrument is used in the MHz range.

- The input signal to be analyzed is heterodyned to a higher IF by an internal local oscillator.
- Tuning the local oscillator shifts various signal frequency components into the pass band of the IF amplifier.
- The output of the IF amplifier is rectified and is applied to the metering circuit. The instrument using the heterodyning principle is called a *heterodyning tuned voltmeter*.

Block Diagram

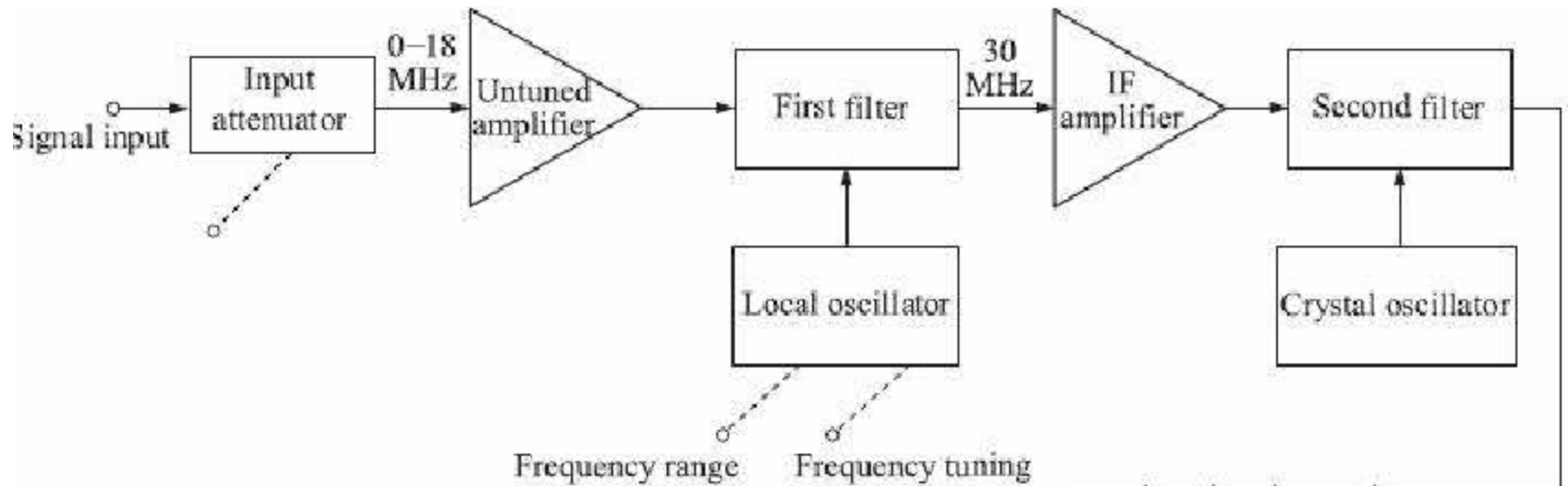

myclassbook.wordpress.com

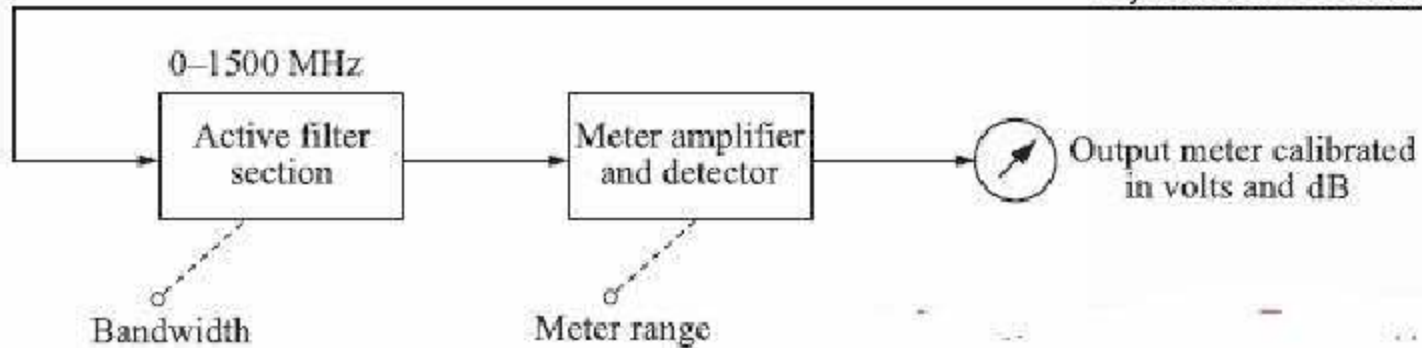

- The operating frequency range of this instrument is from 10 kHz to 18 MHz in 18 overlapping bands selected by the frequency range control of the local oscillator.
- The bandwidth is controlled by an active filter and can be selected at 200, 1000, and 3000 Hz.
- Wave analyzers have very important applications in the following fields:
 - 1) Electrical measurements
 - 2) Sound measurements and
 - 3) Vibration measurements.

Spectrum Analyzer super heterodyne spectrum analyzer

- The modern spectrum analyzers use a narrow band super heterodyne receiver.
- Supereterodyne is nothing but mixing of frequencies in the super above audio range.

Super heterodyne spectrum analyzer

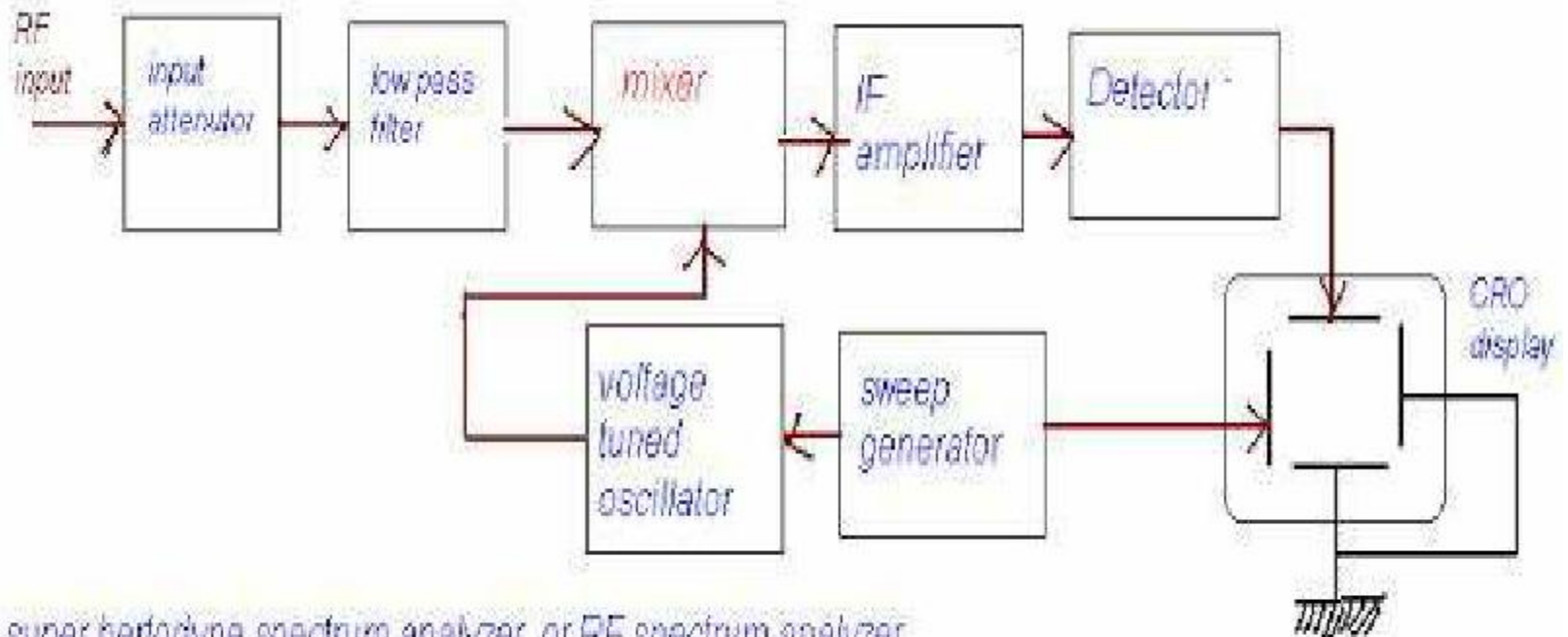

fig. super heterodyne spectrum analyzer or RF spectrum analyzer

- The RF input to be analyzed is applied to the input attenuator. After attenuating, the signal is fed to low pass filter.
- The low pass filter suppresses high frequency components and allows low frequency components to pass through it.
- The output of the low pass filter is given to the mixer, where this signal is fixed with the signal coming from voltage controlled or voltage tuned oscillator.
- This oscillator is tuned over 2 to 3 GHz range.

- This oscillator is tuned over 2 to 3 GHz range. The output of the mixer includes two signals whose amplitudes are proportional to the input signal but their frequencies are the sum and difference of the input signal and the frequency of the local oscillator.
- Since the frequency range of the oscillator is tuned over 2 to 3 GHz, the IF amplifier is tuned to a narrow band of frequencies of about 2 GHz. Therefore only those signals which are separated from the oscillator frequency by 2 GHz are converted to Intermediate Frequency (IF) band.

- This IF signal is amplified by IF amplifier and then rectified by the detector. After completing amplification and rectification the signal is applied to vertical plates of CRO to produce a vertical deflection on the CRT screen.
- Thus, when the saw tooth signal sweeps, the oscillator also sweeps linearly from minimum to maximum frequency range i.e., from 2 to 3 GHz.
- Here the saw tooth signal is applied not only to the oscillator (to tune the oscillator) but also to the horizontal plates of the CRO to get the frequency axis or horizontal deflection on the CRT screen.
- On the CRT screen the vertical axis is calibrated in amplitude and the horizontal axis is calibrated in frequency.

Spectrum analyzer types

- ***Swept or superheterodyne spectrum analysers:*** The operation of the swept frequency spectrum analyzer is based on the use of the superheterodyne principle, sweeping the frequency that is analysed across the required band to produce a view of the signals with their relative strengths. This may be considered as the more traditional form of spectrum analyser, and it is the type that is most widely used. Read more about the [*Swept spectrum analyser*](#)
- ***Fast Fourier Transform, FFT analysers:*** These spectrum analyzers use a form of Fourier transform known as a Fast Fourier Transform, FFT, converting the signals into a digital format for analysis digitally. These analysers are obviously more expensive and often more specialised. Read more about the [*FFT spectrum analyser*](#)

- ***Real-time analyzers:*** These test instruments are a form of FFT analyzer. One of the big issues with the initial FFT analyzer types was that they took successive samples, but with time gaps between the samples. This gave rise to some issues with modulated signals or transients as not all the information would be captured. Requiring much larger buffers and more powerful processing, real-time spectrum analyzer types are able to offer the top performance in signal analysis. Read more about the [Real-time spectrum analyser](#)
- ***Audio spectrum analyzer:*** Although not using any different basic technology, audio spectrum analyzers are often grouped differently to RF spectrum analyzers. Audio spectrum analyzers are focused, as the name indicates, on audio frequencies, and this means that low frequency techniques can be adopted. This makes them much cheaper. It is even possible to run them on PCs with a relatively small amount of hardware - sometimes even a sound card may suffice for some less exacting applications.

Magnetic Tape Recorders

- A recorder is used to produce a permanent record of the signal that is measured.
- A record is used to analyze how one variable varies with respect to another and how the signal varies with time.
- The objective of a recording system is to record and preserve information pertaining to measurement at a particular time and also to get an idea of the performance of the unit and to provide the results of the steps taken by the operator.
- The basic components of a general recorder are an operating mechanism to position the pen or writer on the paper and a paper mechanism for paper movement and a printing mechanism.

- A magnetictape recorder is used to record data which can be retrieved and reproduced in electrical form again. This recorder can record signals of high frequency.

Simple Magnetic Recording System

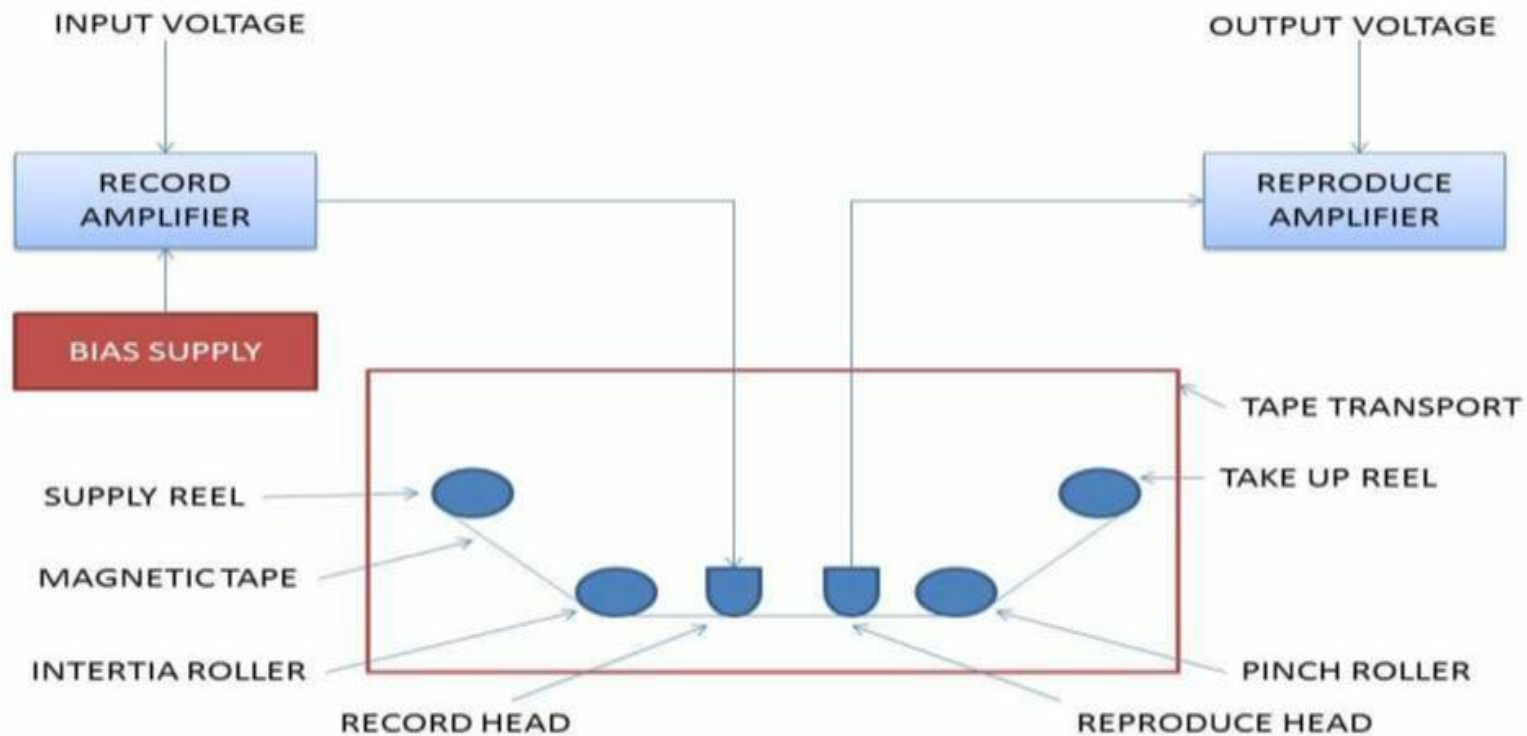

Description

- The magnetic tape is made of a thin sheet of tough plastic material; one side of it is coated with a magnetic material (iron oxide). The plastic base is usually polyvinyl chloride (PVC) or polyethylene terephthalate. Recording head, reproducing head and tape transport mechanism are also present.

Operation of Magnetic Tape Recorders:

- The recording head consists of core, coil and a fine air gap of about 10 micrometer. The coil current creates a flux, which passes through the air gap to the magnetic tape and magnetizes the iron oxide particles as they pass the air gap. So the actual recording takes place at the trailing edge of the gap.
- The reproducing head is similar to that of a recording head in appearance. The magnetic tape is passes over a reproducing head, thereby resulting in an output voltage proportional to the magnetic flux in the tape, across the coil of the reproducing head. Thus the magnetic pattern in the tape is detected and converted back into original electrical signal.

- The tape transport mechanism moves the tape below the head at constant speed without any strain, distortion or wear. The mechanism must be such as to guide the tape passed by the magnetic heads with great precision, maintain proper tension and have sufficient tape to magnetic head contact.

Advantages of Magnetic Tape Recorders:

- Wide frequency range.
- Low distortion.
- Immediate availability of the signal in its initial electrical form as no time is lost in processing.
- The possibility of erase and reuse of the tape.
- Possibility of playing back or reproducing of the recorded signal as many times as required without loss of signal.

Applications of Magnetic Tape Recorders:

- Data recording and analysis on missiles, aircraft and satellites.
- Communications and spying.
- Recording of stress, vibration and analysis of noise.